



FACT SHEET

Cab FH-XXL



There is a choice of interior colours available as an option. For more information, see the interior trim fact sheet.

The FH Globetrotter XXL cab, FH-XXL, is a sleeper cab with extra height and extra length designed for national and international long haul and distribution operations.

The cab offers a very high level of comfort with ideal driving position, anatomically designed seats, low noise level, high-capacity climate control system and a world-class safety level. The interior height is 220 cm (211 cm on the engine compartment cover).

The Globetrotter XXL cab, FH-XXL, is aerodynamically designed with smooth surfaces and rounded corners at the front. The windscreen is bonded to the body, which means less risk of wind noise and better crash protection. The sky window, or roof hatch, is not only intended for ventilation, it is also an escape route.

The interior of the cab is designed with the focus on the driver. The instrument panel offers a good overview and is designed to ensure that the driver obtains the right information in every situation. The cab has a modern interior with materials that are durable and easy to maintain, and offers generous storage space. Much effort has been spent on choosing the material in order to minimize gas emissions from the interior fitting and to reduce risks of contact allergies.

The driver has very good all-round vision through the large windscreen, large rear-view mirrors and close-view mirrors for the front and on the passenger side. The instrument panel is sloped downward to the windscreen and thus improves close-quarter visibility. The effective main headlamps provide a concentrated, long-range beam of light. Bi-Xenon lights, Dynamic Bending Lights and Static Cornering Lights are offered as options. The cab is crash-tested and has an injury-preventing design using energy-absorbing materials. The cab sections are made of galvanised sheet metal which provides good basic protection against corrosion. The entire cab has been given an anti-corrosion treatment and topcoat is applied

FEATURES AND BENEFITS

- Cab safety in every detail protects the driver.
- Comfortable and ergonomically designed driver environment with logical and easy-to-use controls.
- Aerodynamically designed cab exterior contributes to good fuel economy and increased profitability.
- Comfortable entry with anti-slip and illuminated steps.
- Very spacious interior with an advanced climate system.
- Driver seat with a generous adjustment range.
- Wide door opening angle and tilt-away steering wheel aid entry into the cab.
- Comfortable sleeping accommodation for one or two persons, upper bunk available as an option.
- Lower bunk widened 250 mm and lengthened 130 mm for superior sleeping comfort.
- Lower bunk with a smooth pillow on top of every spring unit, which will adapt to the shape of your body, delivering a remarkable level of comfort.

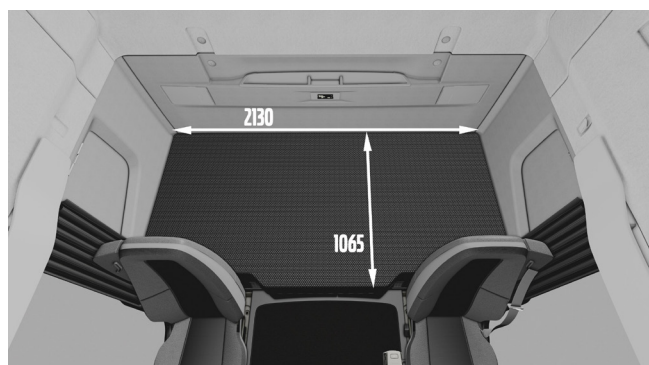

FACT SHEET

Cab FH-XXL



The modern instrument panel offers excellent ergonomics.

using a method that provides the highest level of quality and maximum service life.

Integrated in the front bumper carrier is a very robust Front Under-run Protection System (FUPS) made of aluminium to prevent vehicles from become wedged under the front in the event of a collision. Service points that require the driver's attention are easily accessible behind the front hatch. For easy repair the bumper is divided into three parts and is available in plastic or steel.

Service and repairs of components in the engine compartment are simplified thanks to a generous cab tilt angle of 70°.

Clear instrumentation

The cab's instruments have a simple and logical design with convenient and easy-to-use controls. Driver information is provided via two clear displays on the instrument panel, one of them in front of the driver (main instrument including DID, Driver Information Display) and one to the right (SID, Secondary Information Display). Dynafleet and the audio system are fully integrated in the instrumentation.

The electrical distribution unit is positioned in an easily accessible and protected location in the middle of the instrument panel together with a variety of electrical components and fuses. The truck has a separate electrical distribution unit for body-related equipment, also fitted in the middle of the instrument panel.



DIN slots and storage units above the windscreen and under-bunk storage units.

Functional interior with good storage facilities

The space above the windscreen features three large storage units and one smaller one with a lid in the lower part of the passenger section, altogether with a volume of 180 litres. The large outer storage compartments have jalousie doors and the middle one has a lid. Below these storage units there are six DIN slots, one of which is reserved for the tachograph. The centrally mounted DIN slots can be replaced with open storage compartments (option). A factory-fitted microwave can be ordered (option). The sunvisors are integrated in the front overhead storage unit above the windscreen, The sunvisor can be either manually or electrically controlled.

Cup holder and space for small items and a hidden storage unit near the floor are integrated in the instrument panel. The sleeping area has four big storage compartments for magazines etc. and above the doors two practical storage units are available. Under the bed there are large storage bins with space for a refrigerator and a safe (option). For the FH-XXL the outermost storage areas have been increased with 50 litres on each side, thanks to the cab rear wall moved backwards 250 mm. Additional storage facilities are available as options, for example non-heated storage compartments with external access on each side of the cab (option). The release mechanism is placed in the door-opening area. The rear overhead storage unit has horizontal jalousie doors and a storage capacity of 245 litres (RUS-HIGH standard).

Adjustable steering wheel for an ideal driving position

The angle and height of the steering wheel column, as well as the tilt of the steering wheel, can be adjusted with a foot pedal on the left of the steering column. The height adjustment range is 90 mm and the column's tilt angle range is 28°. The steering wheel tilt angle is 20°. The steering wheel is available with or without an airbag. Integrated controls in the steering wheel provide safe and comfortable operation of cruise control, phone and radio functions, and the menus in the Driver Information Display (DID) and Secondary Information Display (SID).

FACT SHEET

Cab FH-XXL



Reclining lower bunk.

Comfortable and flexible sleeping area

The cab can be equipped with a fixed or reclining bunk and an upper bunk as option. The lower bunk is firm with a pillow on top of every spring unit, delivering a remarkable level of sleeping comfort.

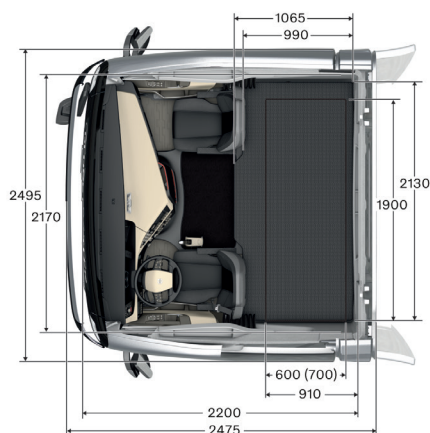
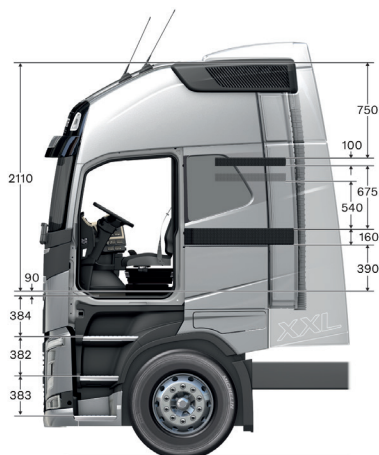

A smoke detector on the side wall (driver side) is standard equipment.

Pleasant working environment with comfortable climate

The sound level in the cab is pleasantly low. The mirror housings are ultra-slim, providing a very wide area of vision with a minimum of blind spots. A control panel for operating mirrors and side windows is integrated in the door panel on the driver's side. The climate system is fully integrated in the truck's ventilation system. This means that hot or cold air is evenly distributed in the cab. There is a choice of three alternative climate systems:

- Air conditioning with manual control.
- Air conditioning with automatic temperature control.
- Air conditioning with automatic temperature control and control of the air quality.

The climate system can also be complemented with a fully integrated system for cab parking heater and cab parking cooler.

Ergonomically designed seats

The seats are ergonomically designed with efficient side support and are available with a variety of specifications (air suspension, ventilation in the seat, heating etc). Seat upholstery can be specified in vinyl, textile, soft textile and leather. A seat with an integrated seat belt is also available as an option.

Low and convenient entry

Entry into the Volvo FH-XXL cab is low, with three anti-slip steps made of aluminium. All footsteps and the ground close to the vehicle are illuminated. The steps protrude somewhat so they are visible from inside the cab, making the exit safer. There are sturdy grab-rails on both sides of the door opening. For more convenient entry, the steering wheel can be tilted out of the way, towards the windscreen.

SPECIFICATION

| | |
|--|------------------|
| Designation..... | FH-XXL |
| Truck model | FH |
| Cab type..... | Globetrotter XXL |
| Bed dimensions, lower (max.) | 1065x2130x160 mm |
| Bed dimensions, upper | 600x1900x100 mm |
| Door opening angle | 75° |
| Total height with configuration as below | 3870 mm |
| Chassis | Medium |
| Tyres | 315/70 R22.5 |
| Front suspension..... | FST-PAR |
| Front axle installation..... | Low |

VOLVO

Volvo Truck Corporation

volvotrucks.com

Volvo retains the right to modify design and specifications without prior notification.